

# 一次入学試験問題

1



( )

( )

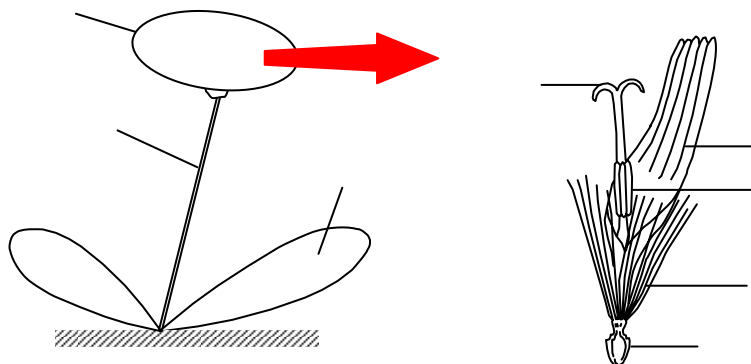

タンポポ

タンポポ

タンポポ

( ) ( )  
 ( ) 30 21

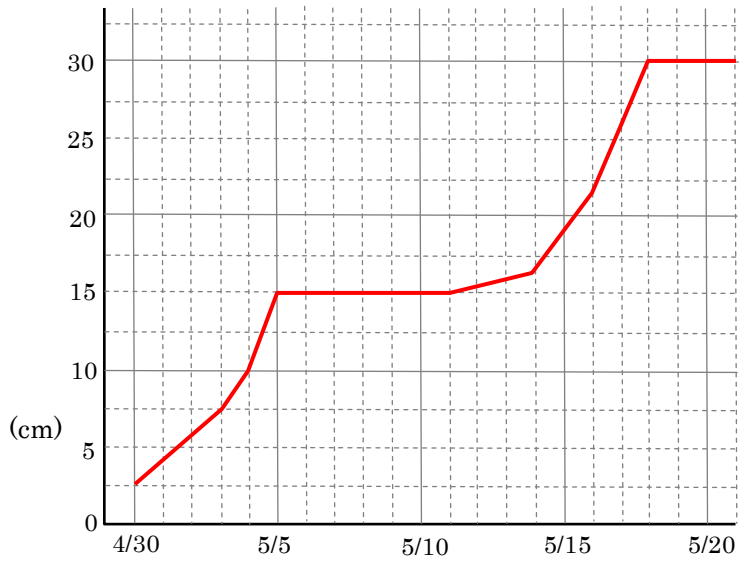
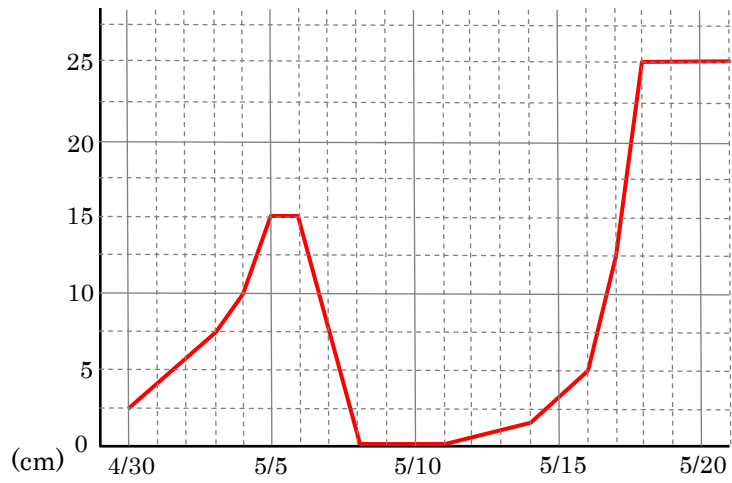
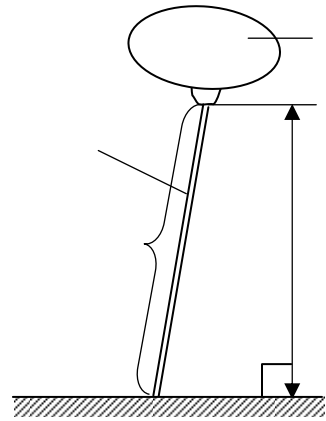

( 15cm 15cm)

10  
18

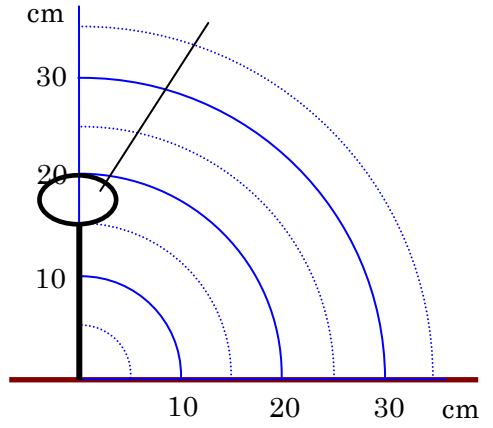

	◊	□	◎

18

1	1
_____	_____



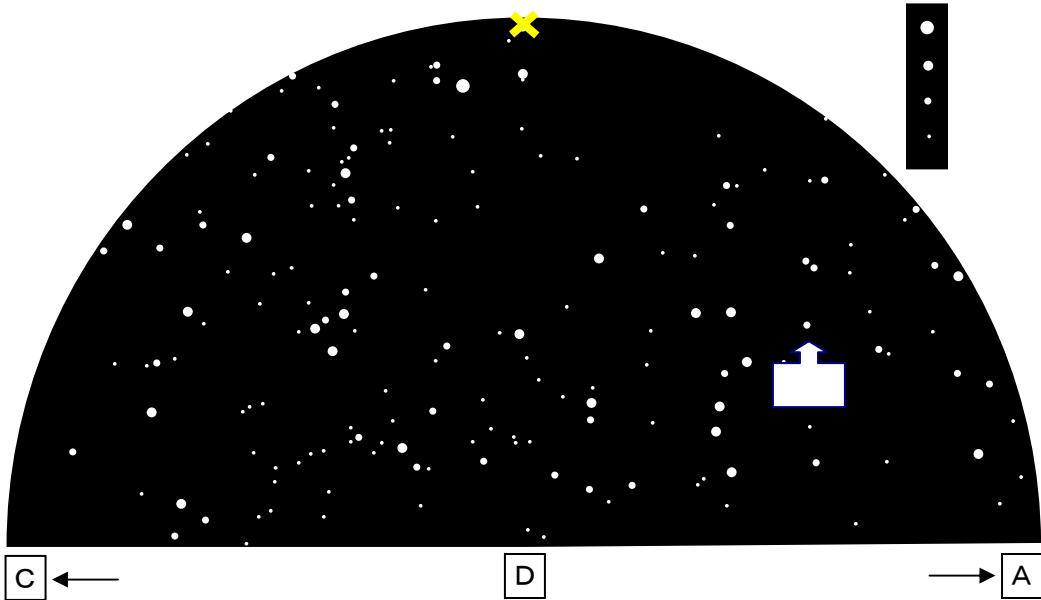
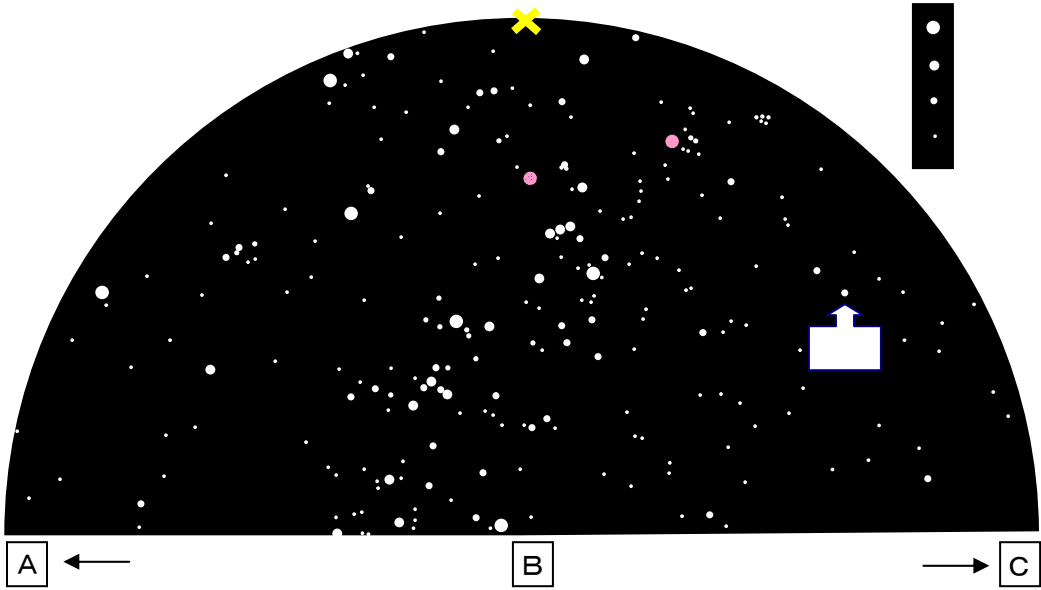

( )

( )

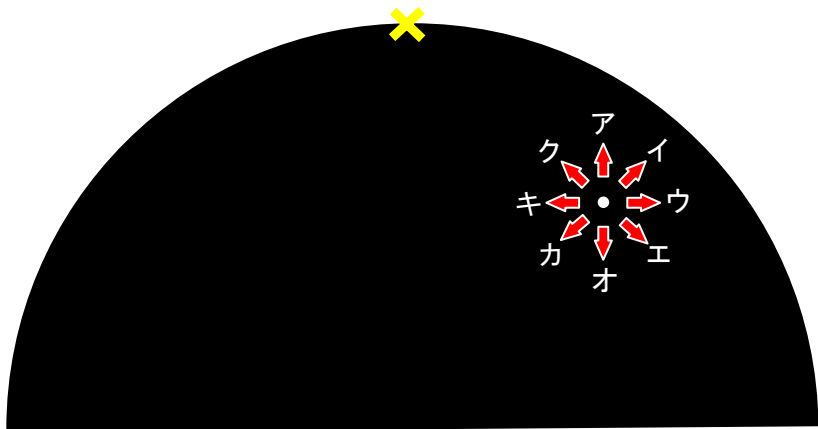

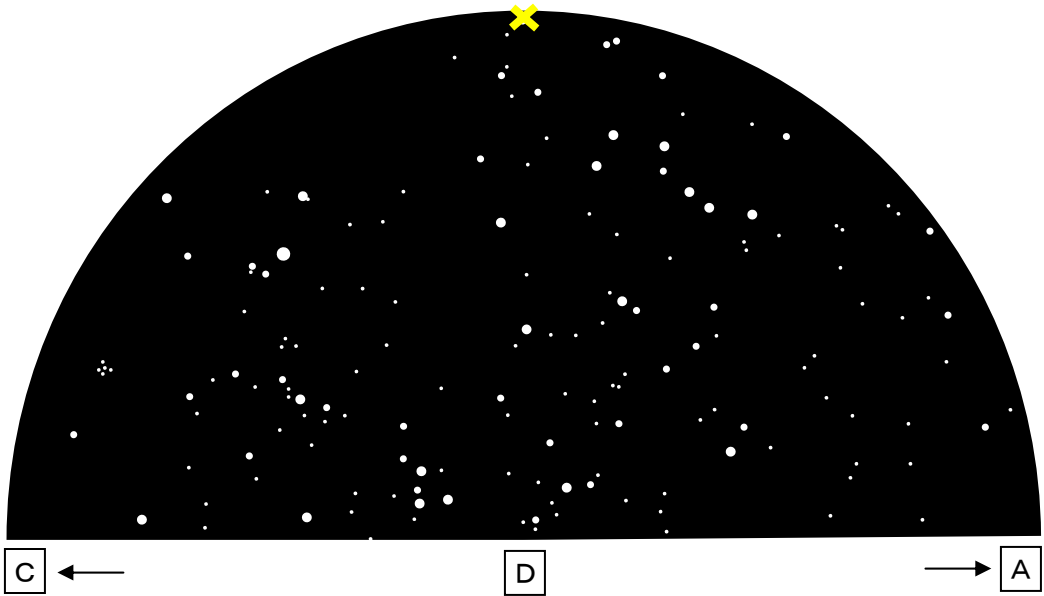

20 20



cm <sup>3</sup>		15	25	45	50
		15	25	45	50
		18	30	54	60
		10.5	17.5	31.5	35

cm<sup>3</sup>

cm <sup>3</sup>	10	15	25	25	30
	11	16.5	20	37.5	24

$20\text{cm}^3$       30

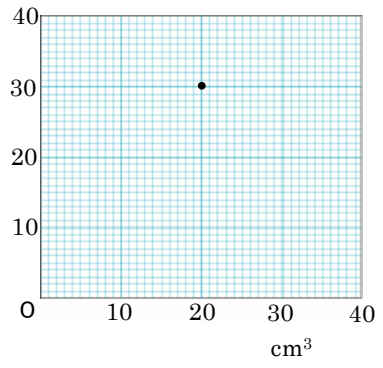

$\text{cm}^3$

$\text{cm}^3$

$\text{cm}^3$

cm<sup>3</sup>

cm<sup>3</sup>

cm<sup>3</sup>

cm<sup>3</sup>

cm<sup>3</sup>

cm<sup>3</sup>

cm<sup>3</sup>

cm<sup>3</sup>

200

148cm

$L_1$  cm

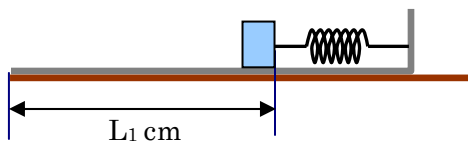
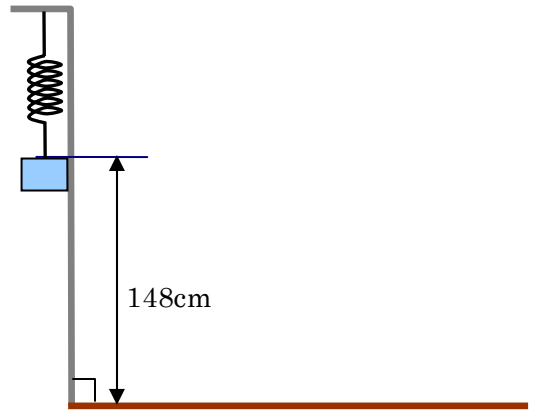
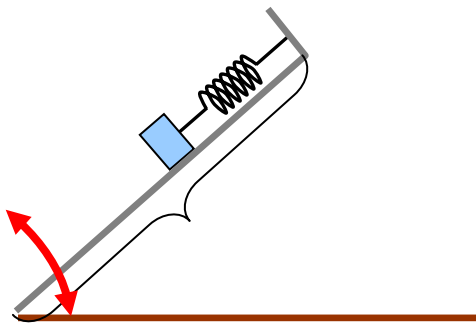

( )

100

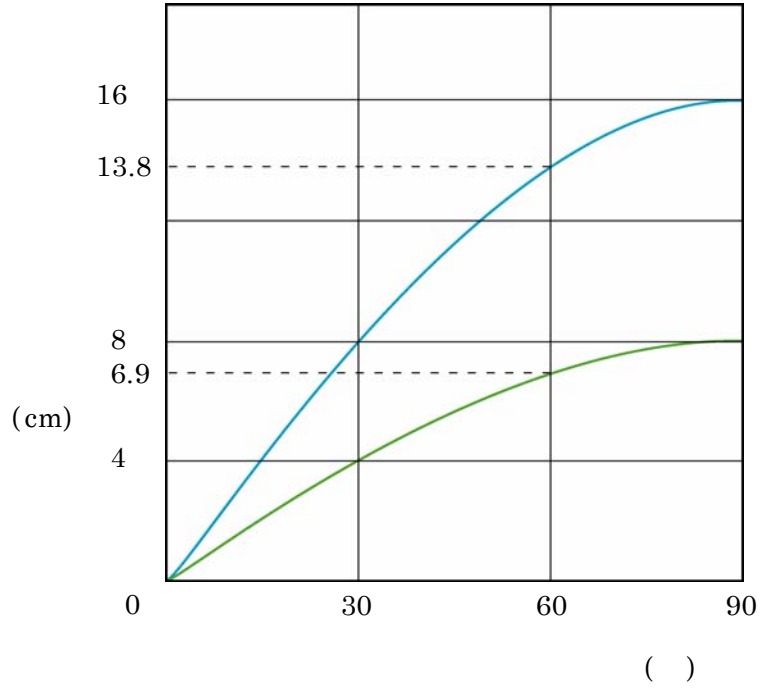

cm

cm

cm

30

cm

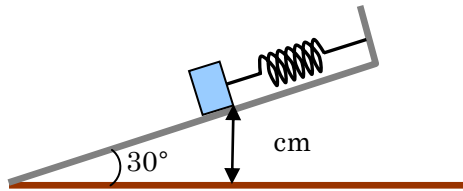

cm

cm

X

30

79 cm

( )

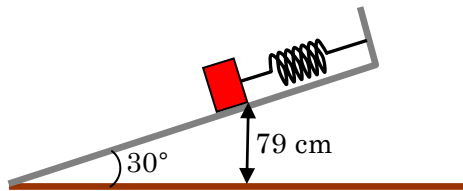

60

( )

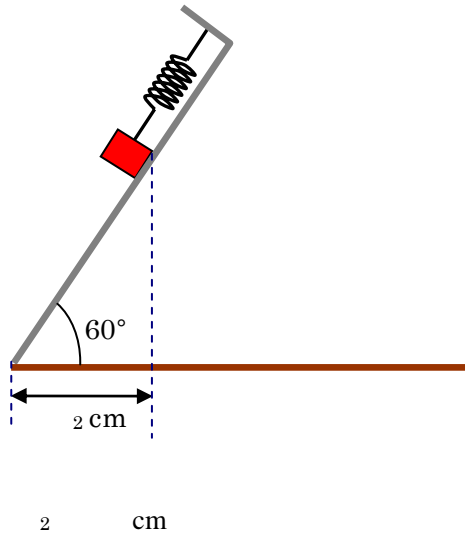

73 cm

75 cm

77 cm

79 cm

81 cm

2010











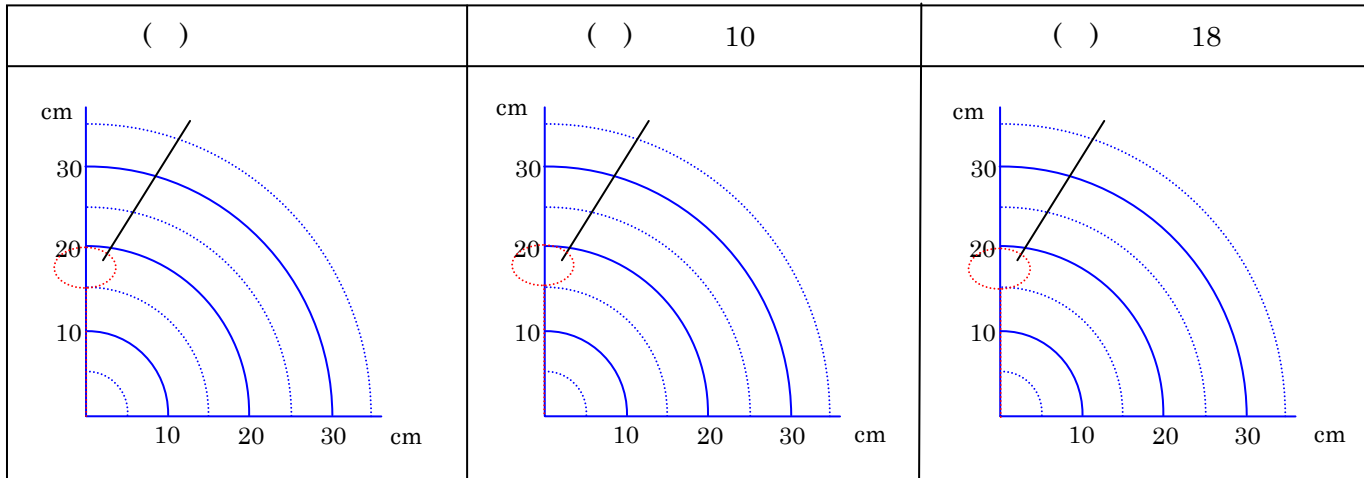



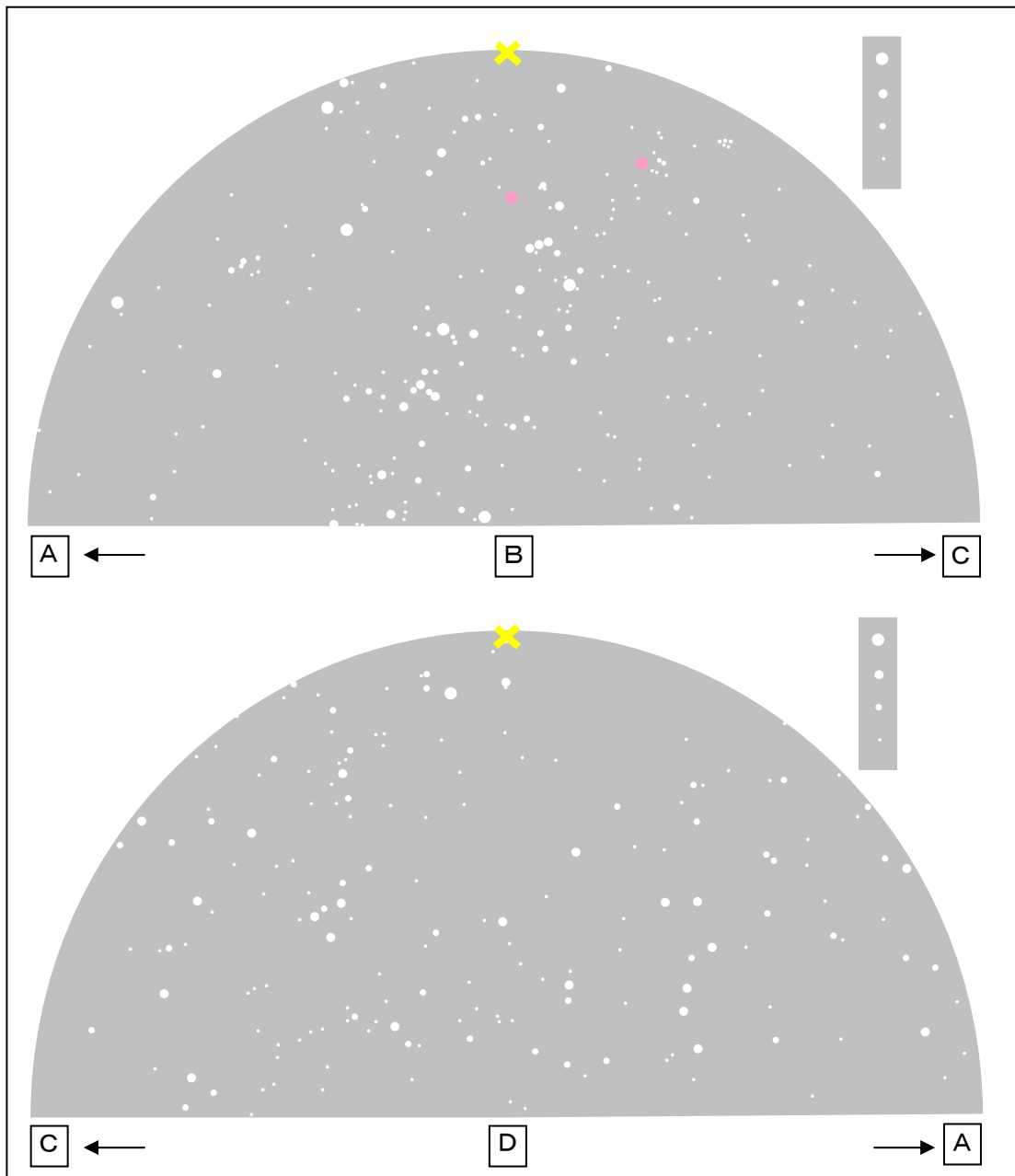

[Empty rectangular box]

[Empty rectangular box]

[Empty rectangular box]

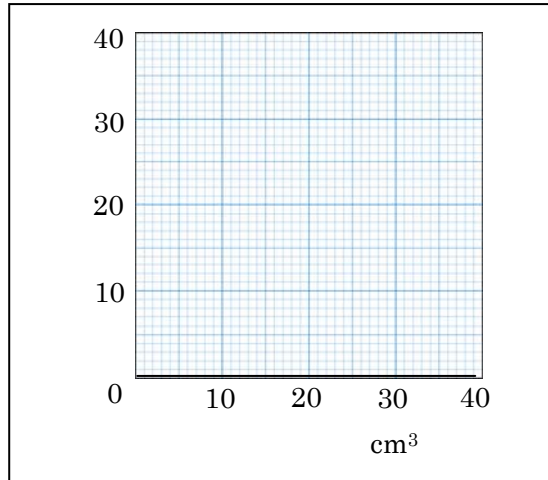

[Empty rectangular box]

[Empty rectangular box]

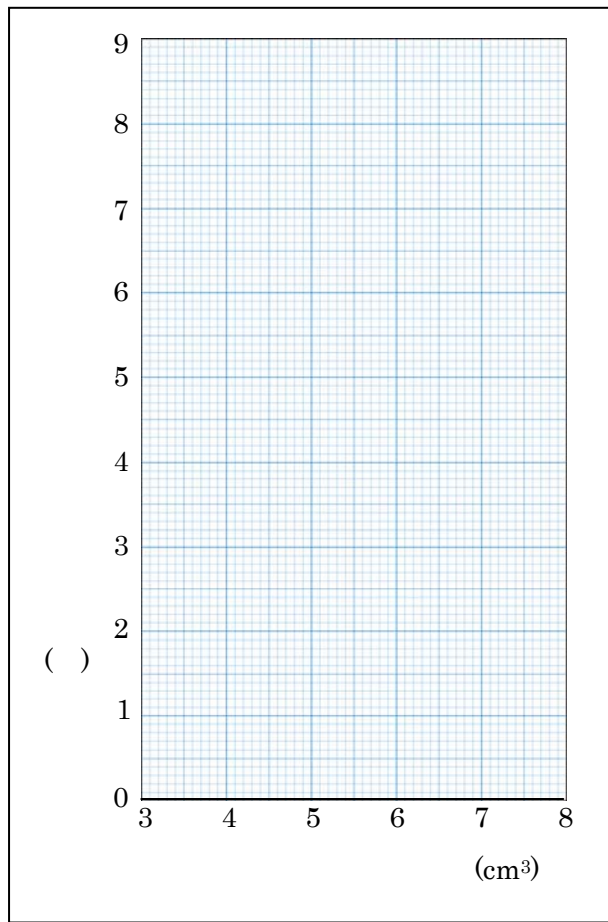
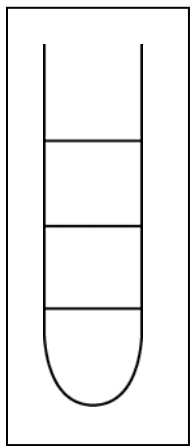

[Empty rectangular box]

[Empty rectangular box]  $\text{cm}^3$

[Empty rectangular box]  $\text{cm}$

[Empty rectangular box]

[Empty rectangular box]  $\text{cm}$

[Empty rectangular box]

[Empty rectangular box]  $\text{cm}$

[Empty rectangular box]  $\text{cm}$

[Large empty rectangular box with a horizontal line near the bottom right corner]

[Empty rectangular box]